

Straight tuck end boxes

Free format selection

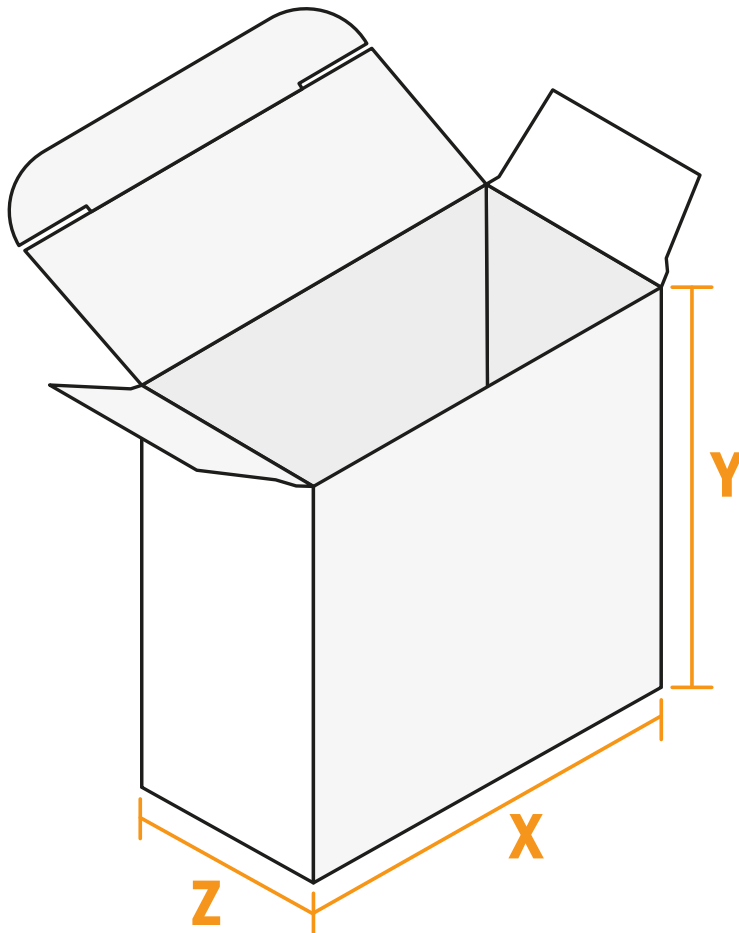

Z width
X length
Y height

- Free format selection
- **Safety margin**
Maintaining 4 mm space between the text/information and the edge of the trimmed format prevents undesirable cuts.

Please note:

- Allow for trim allowance and safety margin according to instructions.
- Arrange background graphics, images or graphics up to the edge of the data format.
- Tolerances may occur during production due to cutting, punching and folding processes.
- This sketch is not drawn to scale.
- Printing data: Instructions and templates can be found under the menu item "Printing data" at www.onlineprinters.com.

Straight tuck end boxes

Free format selection

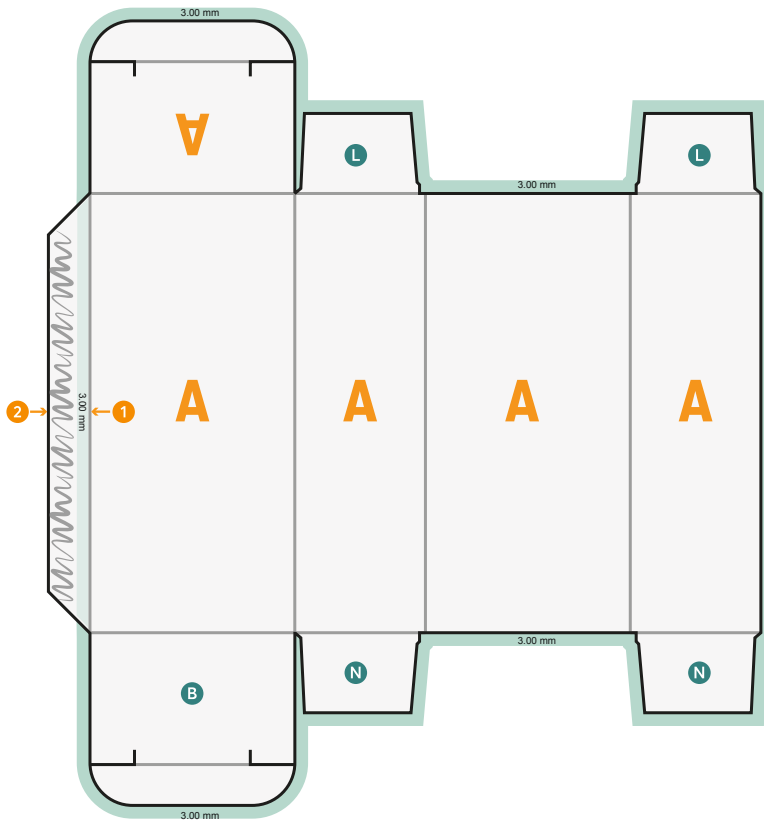

- B** Basement
- N** Invisible
- L** Limited visibility area
- bleed**

- 1** The print design must protrude 3 mm into the inner edge of the adhesive flap (overfill)
- 2** The rest of the adhesive flap must remain unprinted
- 3** Bleed 3 mm on all sides
- 4** Black elements must be created with 100 % black only (e.g. barcodes such as EAN, QR-codes, text etc.)
- 5** Ink application 300 % max.
- 6** Die-cutting line/crease:
 - a) DO NOT remove from the original and later artwork b) must be set to overprint
 - b) must be set to overprint
 - c) must be created as a path/curve
 - d) must be created with 100 % spot colour (die-cutting line: 100 % magenta, crease: 100 % cyan + 100 % yellow)

- Free format selection
- **Safety margin**
Maintaining 4 mm space between the text/information and the edge of the trimmed format prevents undesirable cuts.

Please note:

- Allow for trim allowance and safety margin according to instructions.
- Arrange background graphics, images or graphics up to the edge of the data format.
- Tolerances may occur during production due to cutting, punching and folding processes.
- This sketch is not drawn to scale.
- Printing data: Instructions and templates can be found under the menu item "Printing data" at www.onlineprinters.com.